

edge banders - sizing edge banders

olimpic 500plus / olimpik 500

automatic edge banders



REV. N.00 - 09.2023



SCM GROUP SPA
via Casale 450 - 47826 Villa Verucchio, Rimini - Italy
tel. +39 0541 674111 - scm@scmgroup.com
www.scmwood.com



00L0877557D



**THE PERFORMANCE
YOU WERE WAITING FOR**



A QUALITY LEAP IN EDGE BANDING

olimpic 500plus / olimpic 500
automatic edge banders

olimpic 500plus



olimpic 500



olimpic 500plus



VERSATILITY PLUS

Perfect glue line with the “SGP” glue pot for EVA or PUR glue.

Zero joint line between panel and edge thanks to the Airfusion+ hot air technology

Machining of narrow panels up to 60 mm and gluing of solid wood edges with up to 12 mm thickness



QUALITY PLUS

Machining of 2 radii in all compositions and with all finishing units (including 2-motor rounding unit) with quick and easy settings.

45° chamfering and panel finish with no edge application.

Processing of panels with protecting film with automatic set-up and easy fine-adjustments on the glue scraping unit.

Top panel finish with hot air brightening unit for plastic edges



USER-FRIENDLY PLUS

Large touch control panels and Maestro active edge software for quick and easy management of all machine functions. Connectivity and synchronisation to company systems.

Narrow workpiece infeed system for inserting small panels into the machine correctly and safely.

A single operator for the complete edgebanding process with panel return device fastback 21 and 25.

olimpic 500

olimpic 500plus / olimpico 500

automatic edge banders



VERSATILITY

The SGP-E glue pot allows the use of different types of colors and glue, EVA or PUR.

Machining of 2 true radii, each with a dedicate tool, thanks to Multiedge device for all working units, including the rounding.

45° chamfering and panel finish with no edge application.

Machining of narrow panels up to 60 mm and gluing of solid wood edges with up to 6 mm thickness.



QUALITY

2-motor rounding unit: corner rounding in straight and shaped panels and chamfering of top and bottom panel sides.

New machine framework for greater stiffness and zero vibration on the panel.

Top finish: one of its kind with the plastic edge brightening unit for a top panel finishing.



USER-FRIENDLY

The automatic edge insertion placed outside the cabin reduces the changeover times in total safety.

Large touch control panels and Maestro active edge software offer the operator an efficient and intuitive work experience, as well as providing connectivity and synchronization to company systems.

A single operator for the complete process with the panel return device fastback 21.

500plus

OVERVIEW OF TECHNICAL FEATURES

DETAILS THAT MAKE THE DIFFERENCE

olimpic 500plus / olimpic 500

automatic edge banders



ID 3000 edge brightening unit
It brightens the colour of plastic edges by heating them with hot air.



RC-N glue scraping unit
It eliminates any glue excessing in the joint between edge and panel. 2 pneumatic working positions for machining panel with protective film.



RAS-A edge scarping unit
Simple and quick change of the machining radius.



Round 2-A unit
2-motor unit and Multiedge device for processing 2 true radii.



R-HP Trimming-Chamfering unit
4 working positions.



Pressure rollers
1 large motorized and frictioned roller and 3 idle rollers for excellent gluing.



AirFusion+
For a zero joint line.



Maestro active edge

An expert operator that guides you to produce quickly and without errors.



Infeed system for narrow pieces
Simple, correct and safe panel insertion.



SGP glue pot
Single device for EVA or PUR glue.

OVERVIEW OF TECHNICAL FEATURES

DETAILS THAT MAKE THE DIFFERENCE



ID 3000 edge brightening unit
It brightens the colour of plastic edges by heating them with hot air.



Nesting kit
To process panels coming from nesting cycle.

RT-V1 premilling unit
A perfect panel surface for an excellent joint line.



Kit for the automatic edge loading
Fast, simple and safety edge changeover.



RC-N glue scraping unit
It eliminates any glue excessing in the joint between edge and panel. Nesting processing.



Maestro active edge
An expert operator that guides you to produce quickly and without errors.



SGP-E glue pot
Perfect joint line and use of EVA and PUR glue.



RAS-A edge scarping unit
Simple and quick change of the machining radius with the replacement of the tool kit.



Round 2-A unit
2-motor unit and Multiedge device for machining 2 different radii, each with a dedicate tool.

R-HP Trimming-Chamfering unit
Quick changeover between 2 different radii, infinite thin edges and solid wood tipping thanks to Multiedge devices.



K-2 Radius end cutting unit
Cut and radius in a single operation.



eye-M-EVO console

MAESTRO ACTIVE EDGE

HMI unified for all SCM machines. A software that assists the operator starting from the editing to the execution of the edgebanding programs.

- **EASY TO USE:** immediate interface with use via touch screen. Graphics and icons designed for easy and comfortable navigation;
- **ZERO ERRORS:** thanks to embedded help and reset procedures that reduce the possibility of error of the operator;
- **MAXIMUM CONTROL OF PERFORMANCE:** thanks to the integrability of the production reporting to any business management system;
- **ADVANCED PRODUCTION ORGANIZATION:** possibility of configuring multiple users with different roles and different responsibilities.

The machine can be equipped with **Maestro connect** IoT technology enabling an access to a wide range of services as well as a faster assistance from SCM Service.



eye-S console

OVERALL DIMENSIONS

olimpic 500plus / olimpik 500

automatic edge banders

olimpic 500plus

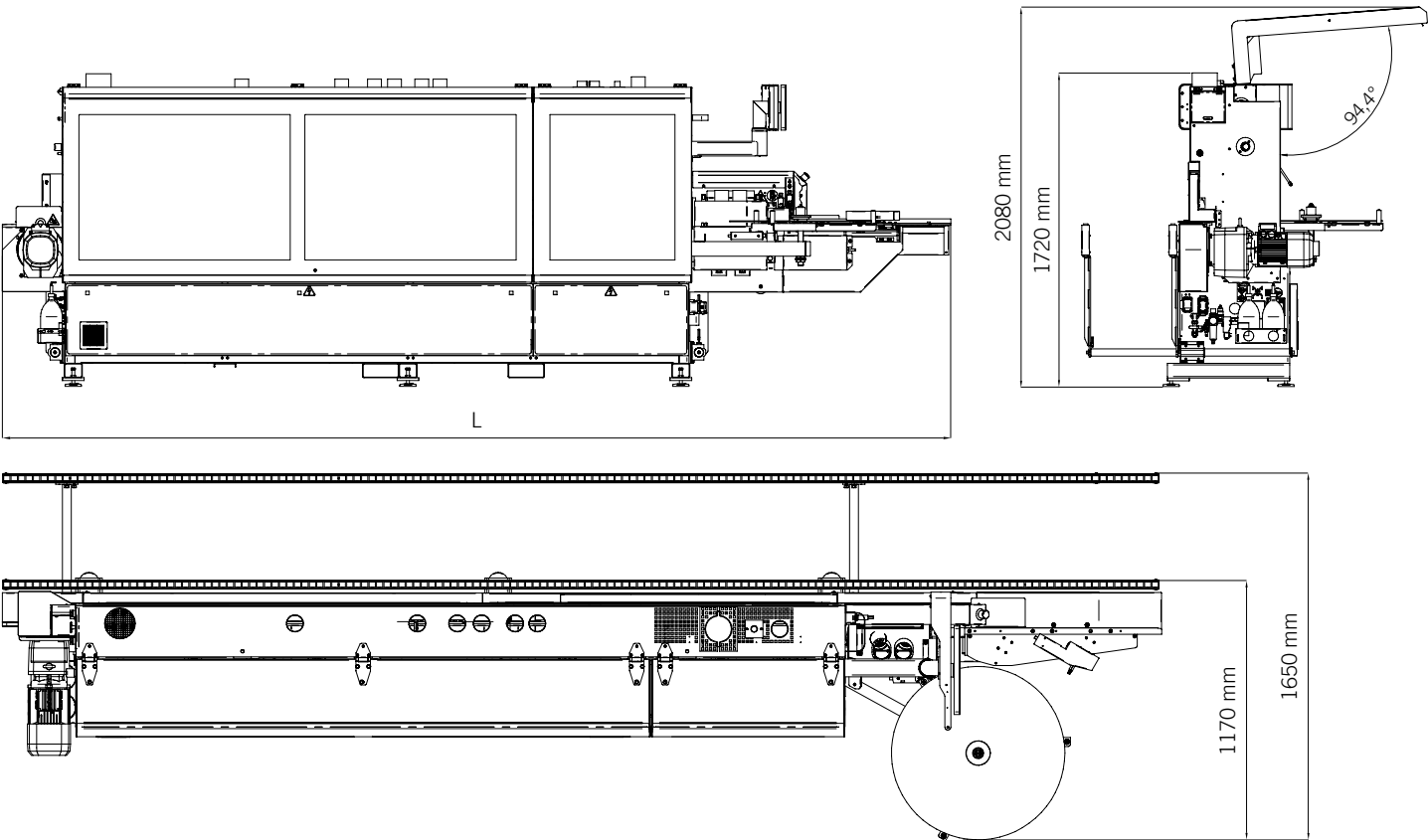

olimpic 500plus E



olimpic 500plus T-E

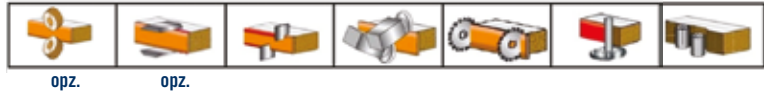

olimpic 500plus T-ER2



olimpic 500plus HP T-ER2



TECHNICAL DATA		
Variable feed speed	m/min	12 - 18
Panel thickness	mm	8 - 60
Minimum panel width	mm	60
Edge thickness	mm	0,3 - 8 (12)
Machine length (L)		
• E and T-E compositions	mm	4.417
• T-ER2 and HP T-ER2 compositions	mm	5.214

olimpic 500

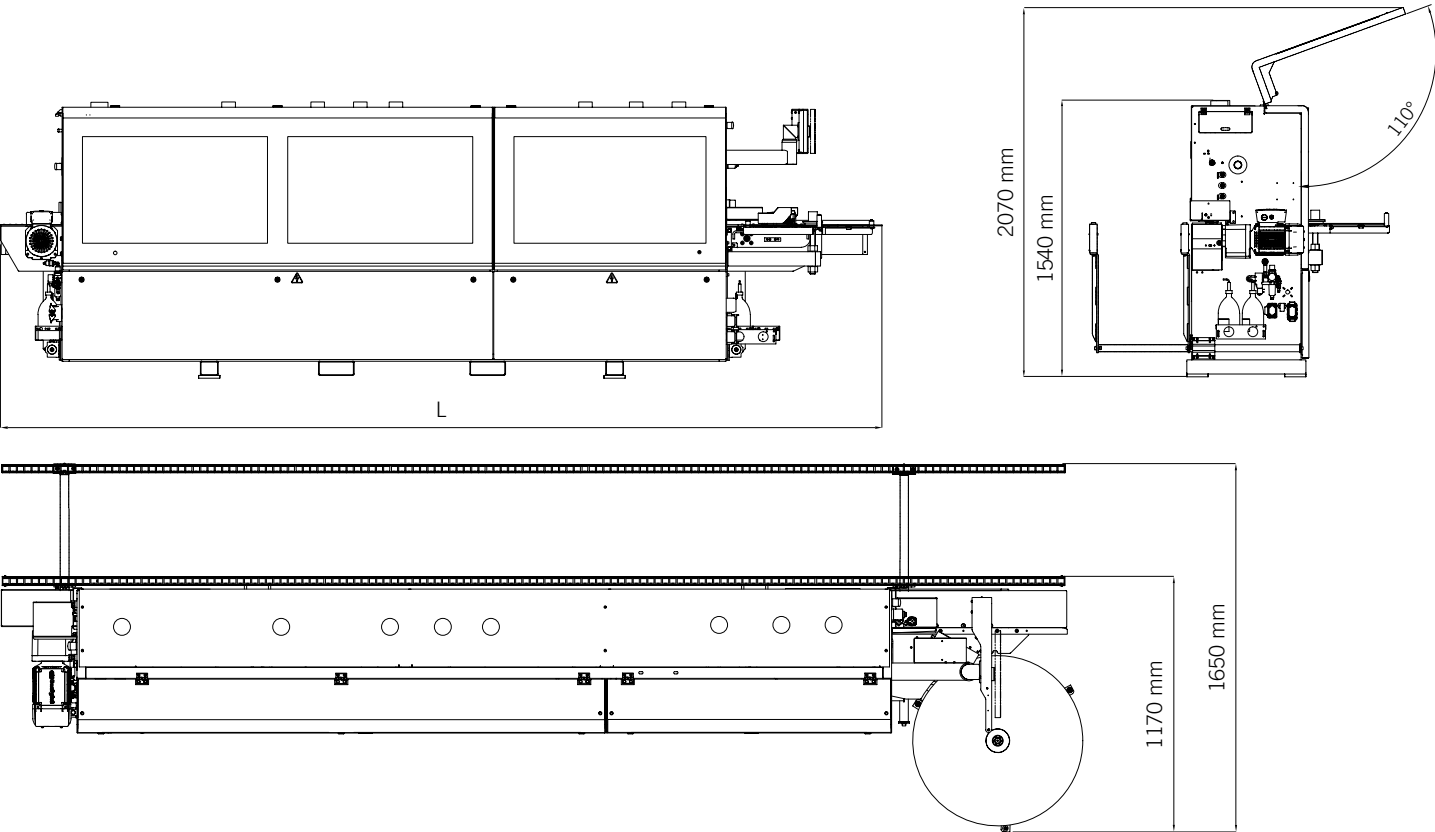

olimpic 500 E

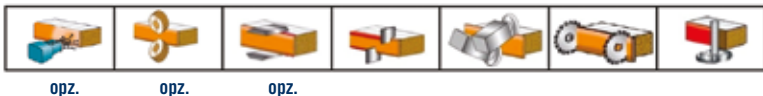

olimpic 500 T-E

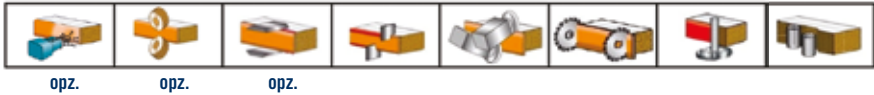

olimpic 500 T-ER2



olimpic 500 HP T-ER2



TECHNICAL DATA		
Feed speed	m/min	12
Panel thickness	mm	8 - 60
Minimum panel width	mm	60
Edge thickness	mm	0,3 - 6
Machine length (L)		
• E and T-E compositions	mm	4.300
• T-ER2 and HP T-ER2 compositions	mm	4.950



WE'LL GO THE EXTRA MILE FOR YOU

SCM OFFERS A FULL RANGE OF **HIGHLY SPECIALISED SERVICES** WITH A QUALITY AND RELIABILITY THAT STEM FROM 70 YEARS OF EXPERIENCE IN THE INDUSTRY.

From installation and production start-up to services and maintenance. From training to the supply of specific original spare parts: **we provide solutions designed around you!**





CONTACT

SCM SERVICE
 via Emilia 77 - 47921 Rimini - Italy
 tel. +39 0541 700100
 scm.service@scmgroup.com
 www.scmwood.com

SCM SPAREPARTS
 Via Emilia, 61 - 47921 - Rimini - Italy
 tel. +39 0541 674111
 spareparts@scmgroup.com
 www.scmwood.com



My Scm

 <p>SERVICE AND MAINTENANCE</p> <ul style="list-style-type: none"> • Remote support • Scheduled maintenance contracts • Warranty extension 	 <p>TRAINING SERVICE</p> <ul style="list-style-type: none"> • Courses for machine operators • Software and programming courses • Training in production start-up
 <p>SPARE PARTS</p> <ul style="list-style-type: none"> • Recommended spare parts list • E-shop • Interactive spare-parts catalogues • Repairs on electronic parts, glue tanks and electro-spindles 	 <p>DIGITAL SERVICES</p> <ul style="list-style-type: none"> • Maestro Connect - IoT platform to be constantly connected with your machines • Smartech - assistance with augmented reality • My Scm portal - opening of service ticket and single point of access to the apps and Services tools