

dmc mb 60/90

automatic brushing machines for profiled panels

wide belt sanders



REV. N. 00 - 01.2022



SCM GROUP SPA
via Casale 450 - 47826 Villa Verucchio, Rimini - Italy
tel. +39 0541 674111 - scm@scmgroup.com
www.scmwood.com



00L0686115E



DMC MB REDEFINES YOUR PRODUCTIVITY

dmc mb 60/90
automatic brushing machines for profiled panels

dmc mb 60



dmc mb 90

**THE BEST PARTNER TO GIVE
SHAPE TO EVERY DETAIL**

6
DMC MB 60

8
DMC MB 90

SOLID

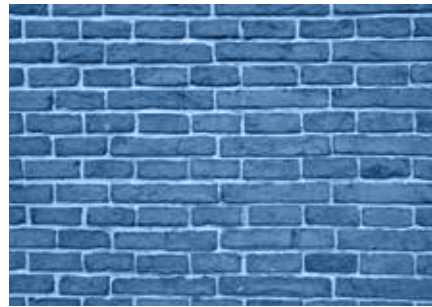

Machine structure is designed to last over time and to grant **reliability** during brushing operations.

MADE IN ITALY



100% made in Italy
Over 60 years' experience in innovating and manufacturing woodworking machines guarantees **top reliability and quality standards**.

RELIABLE



Dmc mb brushing machines are the **ideal solution for the finishing** of assembled kitchen cabinet doors, doors and windows and similar profiled parts (picture frame strips, cableways, matchboardings, skirting boards). Parts can be rough or painted. In this way even the **requests of the most demanded customers are satisfied**.

FLEXIBLE



Wide availability of technological devices which make the dmc mb range **flexible and versatile** for every production process.

LEAN



Simple and dynamic machines configurations to enable customer to obtain a **flawless finished product**.

24
Machine controls

25
Technical data

TECHNOLOGICAL FEATURES

TECHNOLOGICAL ADVANTAGES



Delta electronic control with 7" touch-screen.

Maximum safety with the front and the two rear emergency stop push-buttons.



Maximum freedom of movement, with the gullwing opening and the micro safety switch.



900 mm fixed height worktable.



Available versions
Two versions available, one for sanding with abrasive belts and the other for texturing with steel or tynex tools.



Natural rubber vacuum table with diamond shaped belt: the best piece traction.

TECHNOLOGICAL FEATURES

TECHNOLOGICAL ADVANTAGES

dmc mb 60/90
automatic brushing machines for profiled panels

The machine has been designed to house and combine working units equipped with oscillating discs and brushing rollers, suitable for different sanding applications.



Oscillating brushing unit with dual direction of rotation for double-faced abrasive strips. Available with Simoni and Flextrim abrasives strips.

Electronic auto-set of the units



"Pro-sand" electronic programmer to control by the touch screen the automatic positioning of the units.



Natural rubber vacuum table with diamond-shaped belt, for the best piece traction.



No machine down-time
Extractable discs unit with sliding movement and rapid tools changeover system.

Working table with wide opening, for substantial working thickness processing:
- from 4 to 170 mm (mobile working table)
- from 4 to 2000 mm (fixed working table)

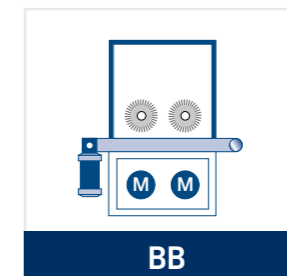
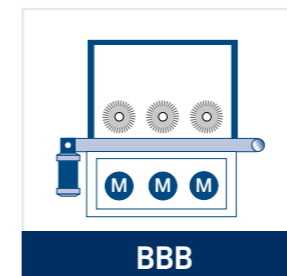
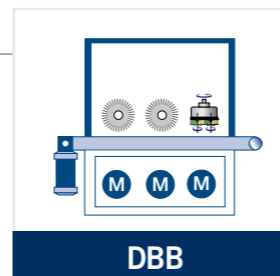

Available versions
Three versions for the finishing of assembled kitchen cabinet doors, doors and windows and similar profiled parts (picture frame strips, cableways, matchboardings, skirting boards). Parts can be rough or painted.

OPERATING UNITS

MB60 AVAILABLE VERSIONS

dmc mb 60/90
automatic brushing machines for profiled panels

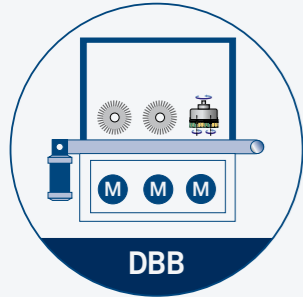

DBB VERSION FOR BRUSH SANDING OR TEXTURING

This version equipped with sliding discs unit and two brushing units is available both for brushing and distressing setting.

mb 60

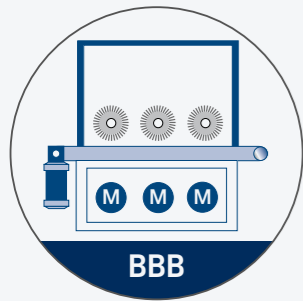

BBB VERSION FOR BRUSH SANDING OR TEXTURING

The three brushes version is perfect for the removal of raised wood fibers and for brushing painted profiled kitchen cabinet doors or significant distressing.

mb 60



DBB VERSION

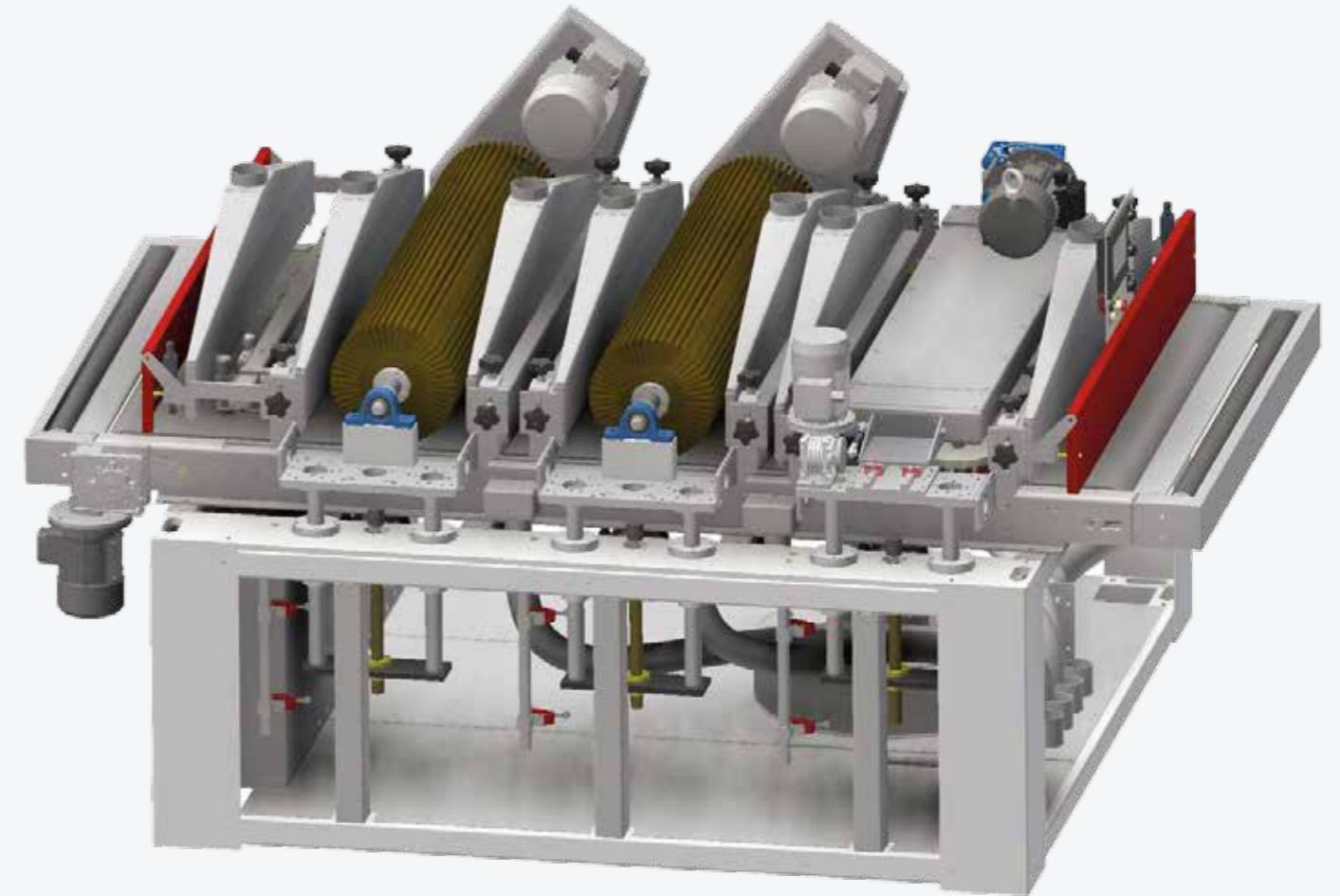

OPERATING UNITS

MB90 AVAILABLE VERSIONS

dmc mb 60/90
automatic brushing machines for profiled panels

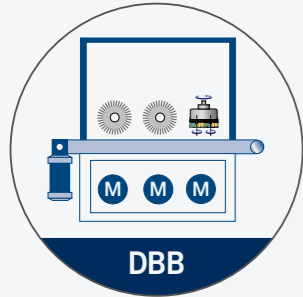

DBB VERSION

This version equipped with sliding discs unit and two brushing units is perfect for the edge-rounding and brushing of rough and painted panels.

mb 90

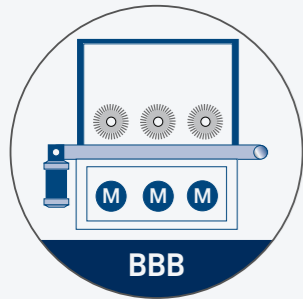

BBB VERSION

The three brushes version is suitable for the removal of raised wood fibers and for brushing painted profiled kitchen cabinet doors.

mb 90

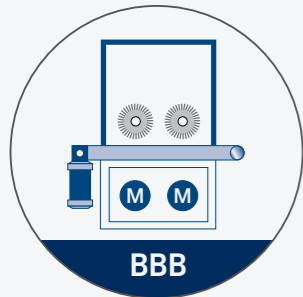

BB VERSION

The two brushes version is excellent for preparing the surface of those panels that need one single brushing pass before moving on to the finishing step.

mb 90

BRUSHES CAN BE AVAILABLE BOTH WITH SIMONI AND FLEX TRIM TOOLS.



DISCS OPERATING UNITS MB60

The discs unit is set for 12 disposable tools with 200 mm of diameter.

For the **brushing process** the unit is driven by a **2,2 kW inverter motor**, while for the **texturing process** is employed a **2,6 kW inverter motor**.

The unit is featured also by an **oscillating movement** by means of a **0,37 kW inverter motor**.

WORKING ENVIRONMENT ALWAYS CLEAN

The discs unit is equipped with double exhaust hoods.

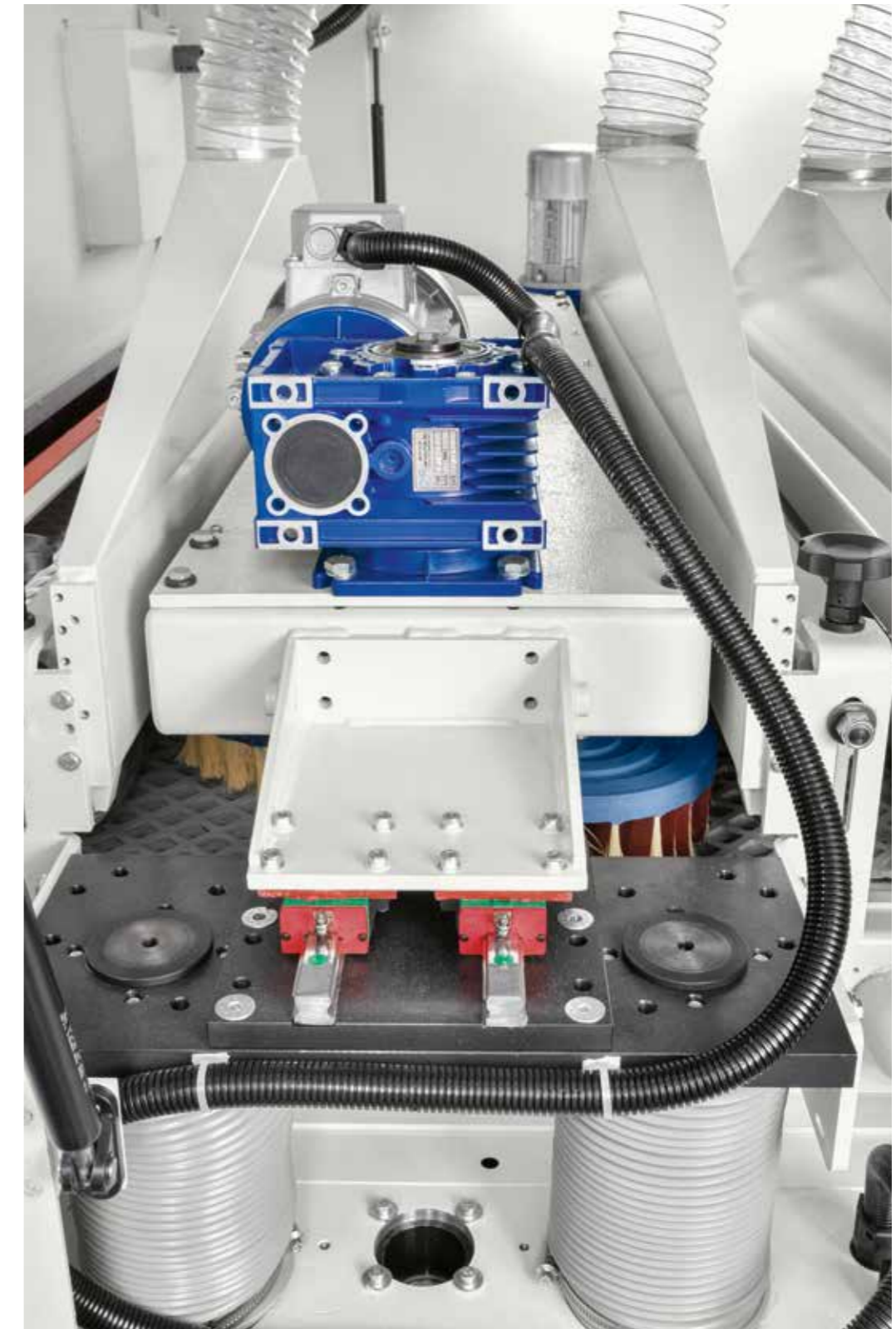

Sliding movement due to an independent motor for greater effectiveness on the edges.

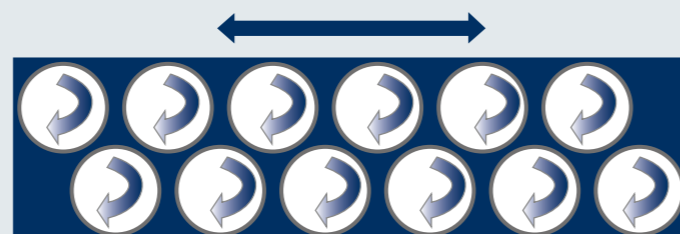

DT17 OPERATING UNITS MB90

Especially suited unit for **kitchen cabinet doors edge rounding**, thanks to the **side oscillating movement** of the unit's supporting structure. It is fitted with 17 counter-rotating discs and allows to reach the most difficult areas of the profiled panel; thus preparing the surface to the brushing process.

SIMPLE AND FAST MAINTENANCE

Due to the **telescopic guides** that enable a rapid extraction of the unit.

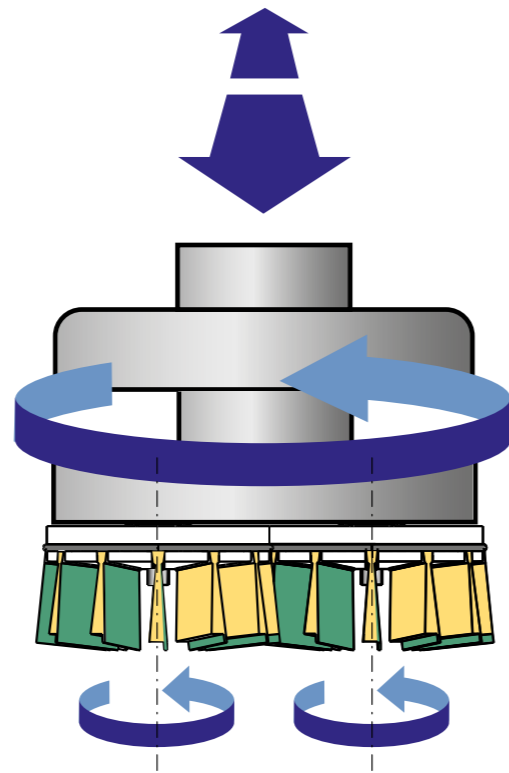

OSCILLATING DISCS UNIT

The unit is featured with **side oscillating movement** and a **double row counter-rotating discs** structure for **greater effectiveness** when rounding the edges and to reach the most inaccessible areas on the profiled panel.

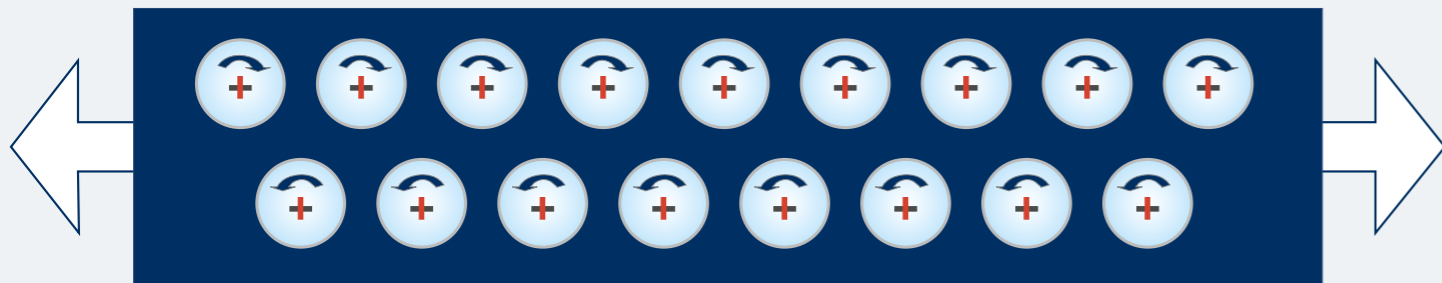

Sliding movement driven by an independent motor.

The **quick-release system** for the brush discs enables **quick machine set-up** while, at the same time, provides maximum reliability and safety of the locking mechanism.

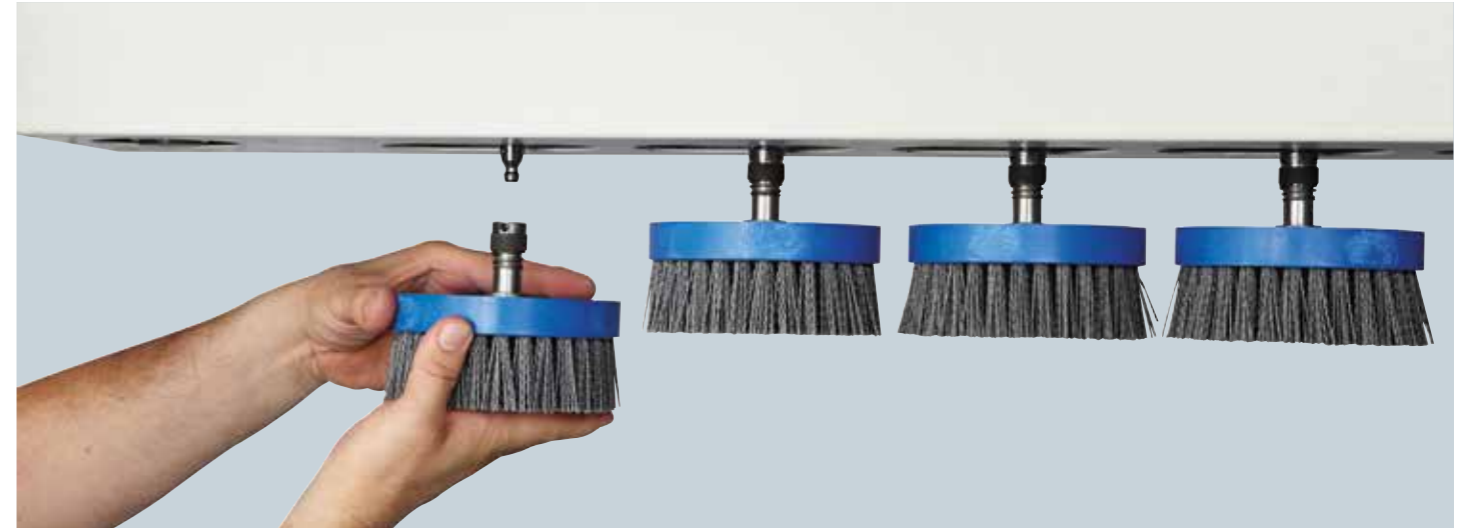

LATERAL EXTRACTION OF THE UNIT

It is carried out by a **telescoping system on recirculating ball bearing guides**, to guarantee **maximum stability and reliability** over time and to **minimize the effort** of the operator.



BRUSHING OPERATING UNIT

MB60

dmc mb 60/90
automatic brushing machines for profiled panels

The **brushing unit** has a diameter of 300 mm and is driven by two different motors according to the process to be carried out. The **2,2 kW motor** is for the **brushing process**, whereas the 11 kW motor is specific **for the texturing process**.

In the brushing configuration, the brush unit is equipped with a **double suction hood** to allow a **dual direction of rotation** and therefore the use of **double-faced abrasive strips**. In the texturing configuration, the units have a single suction hood (inversion is not available).

mb 60

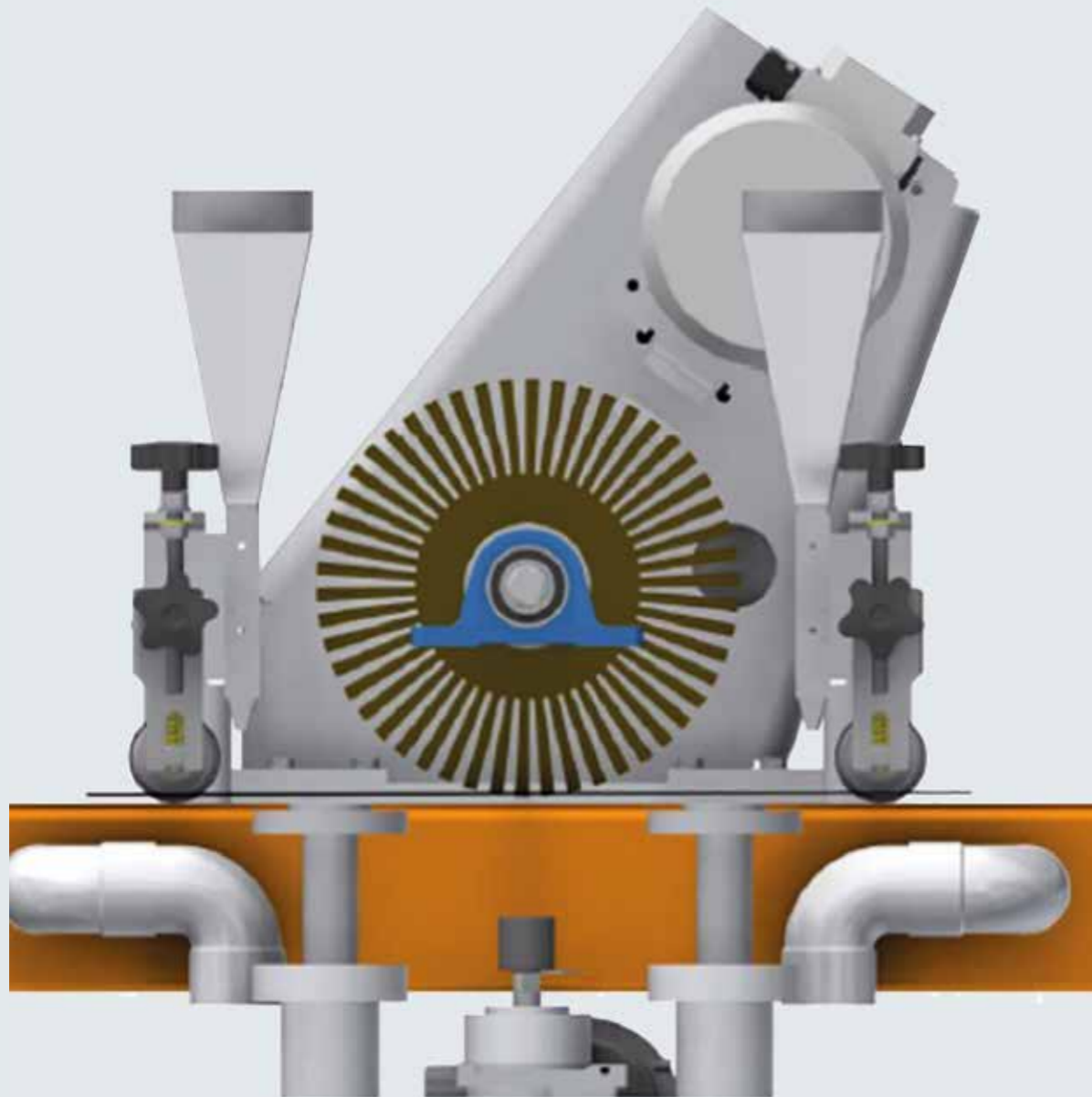

EASY CHANGE-OVER,
by simply removing the ring nut
using the screws provided to
replace the abrasive brushes.

0.2 mm and 0.3 mm **steel brush**
for distressing the panel.



Tynex brush with 120 grit for excellent
panel texturing.



BRUSHING OPERATING UNIT MB90

dmc mb 60/90
automatic brushing machines for profiled panels

Brushing roller unit equipped with an innovative system for the inclination adjustment and the lateral oscillating movement of the brushing roller. The unit guarantees a top class and uniform sanding quality on all parts of the panel.

mb 90



BRUSH ROTATION INVERSION

By reversing the direction of rotation, it is possible to use **double-faced abrasive strips**, which allows to process both rough and painted panels **without having to change tools**.

Brushing operating unit is equipped with an **oscillating system** to improve the effectiveness of the brushes action and to ensure a greater working coverage.



Automatic positioning of the brushing unit for easier setup and faster change of the working programme.

OTHER DEVICES

ROTATING CLEANING BLOWERS AT THE MACHINE OUTFEED

For an optimum cleaning of the work pieces just processed.



mb 60



mb 90

INTERNAL VACUM DEVICE

Ducted work table suction system for homogeneous vacuum over the entire worktable.



mb 60

mb 90

VACUUM TABLE WITH DIAMOND-SHAPED BELT: NO SLIPPING OF THE WORK PIECES

The best traction surface and the maximum stability for the panels are provided by the special geometry of the diamond-shaped profile of the transport belt in natural rubber.



mb 60

mb 90



MACHINE CONTROLS



DELTA ELECTRONIC CONTROL

7" touch screen for total machine control and setting working parameters.

This control allows an easy and intuitive process management.

mb 60



"PRO-SAND" ELECTRONIC PROGRAMMER

Technology at your service.

Powerful and reliable, it is fitted with a touch-screen making all machine functions quick and easy to operate.

- 5,7" or 10,4" LCD colour display
- 120 working programs

mb 90

TECHNICAL DATA

dmc mb 60/90
automatic brushing machines for profiled panels

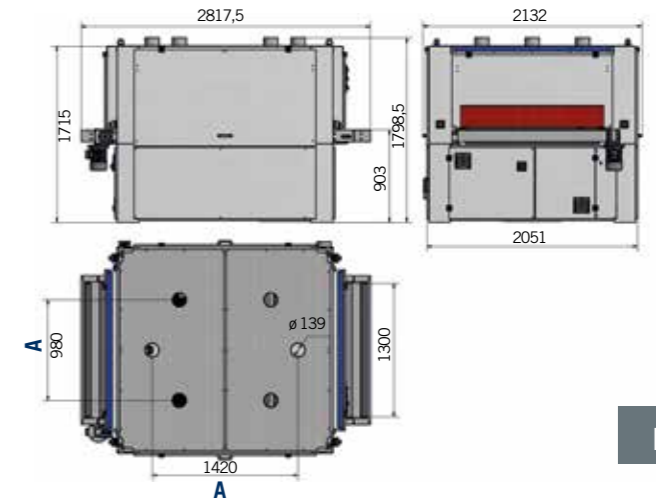

mb 60

MACHINE DIMENSIONS

Dimensions (mm)		
X	2817,5	Machine length with 3 operating units
Y	2051	Overall machine width
Z	1715	Machine height
A	139	Hoods diameter

STANDARD EQUIPMENT AND OPTIONS

dmc	mb 60	mb 90
Working width	1300 mm	1350 mm
Main working units	1-2-3	1-2-3
Oscillating discs unit	12 discs	17 discs
Brushing unit	300 mm	300 mm
Vacuum table	std	opt
Fixed table	std	opt

COMPANY WITH
QUALITY SYSTEM
CERTIFIED BY DNV
= ISO 9001 =

The technical data can vary according to the requested machine composition. In this catalogue, machines are shown with options. The company reserves the right to modify technical specifications without prior notice; the modifications do not influence the safety prescribed by CE Norms.

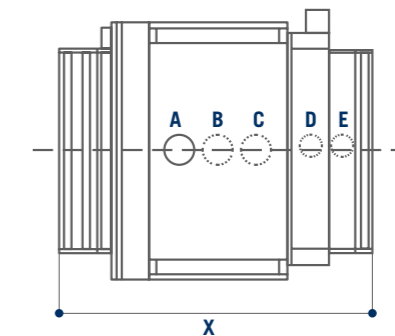

mb 90

MACHINE DIMENSIONS





Dimensions (mm)		
X	2190	Machine length with 1 or 2 operating units
X	2580	Machine length with 3 operating units
Y	1900	Overall machine width
Z	2390	Machine height with mobile table
Z	2390/2590	Machine height with fixed table



scm | service
WE'LL GO THE EXTRA MILE FOR YOU

SCM OFFERS A FULL RANGE OF **HIGHLY SPECIALISED SERVICES** WITH A QUALITY AND RELIABILITY THAT STEM FROM OVER 65 YEARS OF EXPERIENCE IN THE INDUSTRY.

From installation and production start-up to services and maintenance. From training to the supply of specific original spare parts: **we provide solutions designed around you!**

 <p>SERVICE AND MAINTENANCE</p> <ul style="list-style-type: none"> • Remote support • Scheduled maintenance contracts • Warranty extension 	 <p>TRAINING SERVICE</p> <ul style="list-style-type: none"> • Courses for machine operators • Software and programming courses • Training in production start-up
 <p>SPARE PARTS</p> <ul style="list-style-type: none"> • Recommended spare parts list • E-shop • Interactive spare-parts catalogues • Repairs on electronic parts, glue tanks and electro-spindles 	 <p>DIGITAL SERVICES</p> <ul style="list-style-type: none"> • Maestro Connect - IoT platform to be constantly connected with your machines • Smartech - assistance with augmented reality • My Scm portal - opening of service ticket and single point of access to the apps and Services tools

CONTACT
SCM SERVICE
 via Emilia 77 - 47921 Rimini - Italy
 tel. +39 0541 700100
 scmservice@scmgroup.com
 www.scmwood.com

SCM SPAREPARTS
 Via Casale, 450 - 47826 - Villa Verucchio (RN) - Italy
 tel. +39 0541 674111
 spareparts@scmgroup.com
 www.scmwood.com



My Scm







THE STRONGEST WOOD TECHNOLOGIES ARE IN OUR DNA

SCM. A HERITAGE OF SKILLS IN A UNIQUE BRAND
 Over 65 years of success gives SCM the centre stage in woodworking technology. This heritage results from bringing together the best know-how in machining and systems for wood-based manufacturing. SCM is present all over the world, brought to you by the widest distribution network in the industry.

- 65+** years history
- 3** main production sites in Italy
- 300.000** square metres of production space
- 20.000** machines manufactured per year
- 90%** export
- 20** foreign branches
- 400** agents and dealers
- 500** support technicians
- 500** registered patents

In SCM's DNA also strength and solidity of a great Group. The SCM Group is a world leader, manufacturing industrial equipment and components for machining the widest range of materials.

SCM GROUP, A HIGHLY SKILLED TEAM EXPERT IN INDUSTRIAL MACHINES AND COMPONENTS

INDUSTRIAL MACHINERY	INDUSTRIAL COMPONENTS
Stand-alone machines, integrated systems and services dedicated to processing a wide range of materials.	Technological components for the Group's machines and systems, for those of third-parties and the machinery industry.
 WOODWORKING TECHNOLOGIES	 TECHNOLOGIES FOR PROCESSING COMPOSITE MATERIALS, ALUMINIUM, PLASTIC, GLASS, STONE, METAL
	   
	SPINDLES AND TECHNOLOGICAL COMPONENTS ELECTRIC PANELS METALWORK CAST IRON

